

MG44.1.1

GİZLİ PANO MENTEŞESİ (Zamak)
CONCEALED HINGE (Zamak)

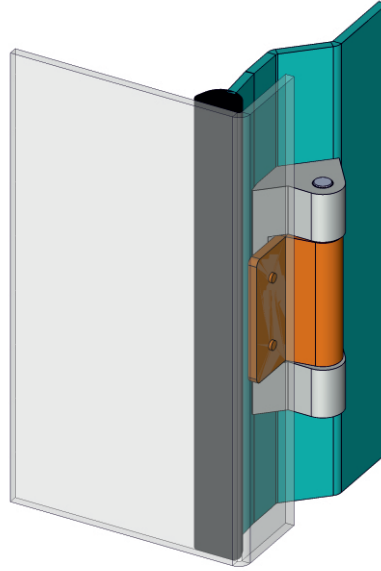

280Kg.

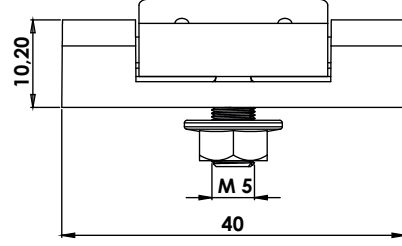
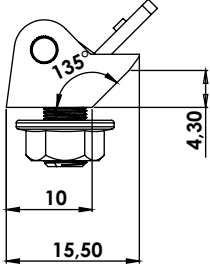
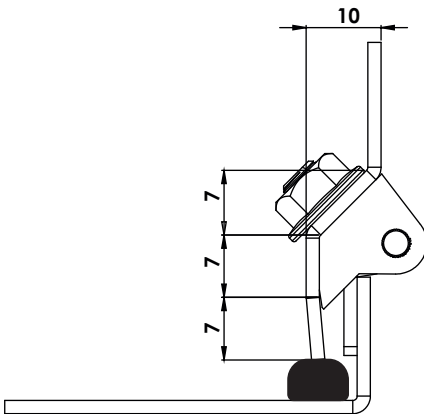

Kullanım Alanları

- * Elektrik Panoları
- * Makina Kapakları

Malzeme

- * Gövde: Zamak
DIN-EN 1774-ZnAl4Cu1
- * Montaj Parçası: St 37 Çelik Levha
- * Gövde Kaplama: Çinko
- * Montaj Parçası Kaplama: Bakır Kaplama
- * Menteşe Dönme Açısı: 180°

Applications

- * Electric Panels
- * Machinery Covers

Material

- * Body: Zamak
DIN-EN 1774-ZnAl4Cu1
- * Assembly Part: Steel St 37
- * Finish: Zinc Plated
- * Assembly Part: Copper Plated
- * Hinge Rotation Angle: 180°